

Listing of large-size profiles

ST50

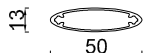

ST 100

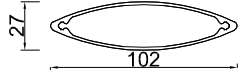

ST 100W

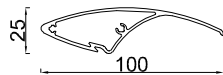

ST 100AC

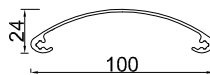

ST 120

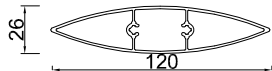

ST 150

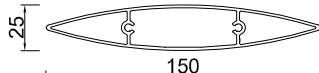

ST 150_30

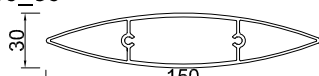

ST 180

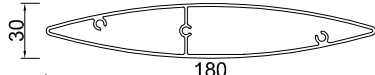

STB 200A

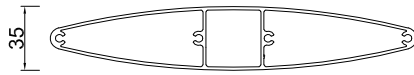

ST 200 ECONOMY

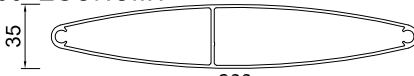

ST 250

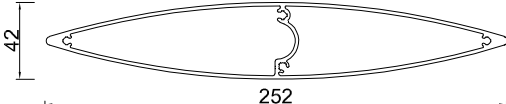

ST 250 ECONOMY

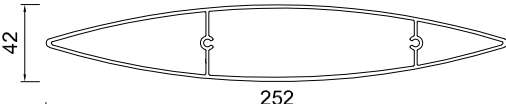

STB 300

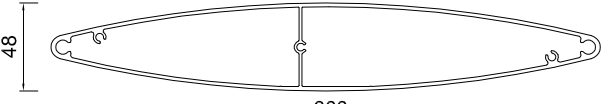

ST 300

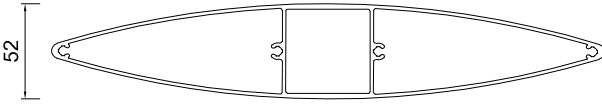

ST 300 BS

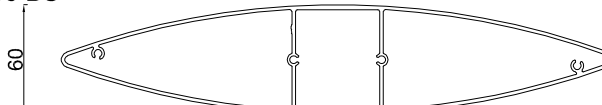

ST FR 110 INV

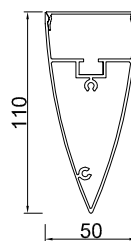

ST FR 110 FIN

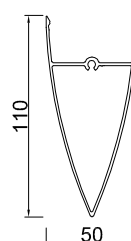

ST FR 225 FIN

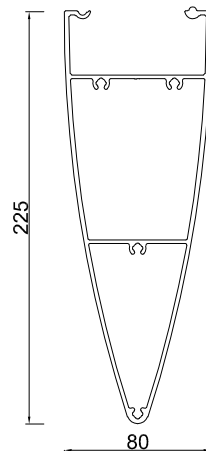

ST FR 250 FIN

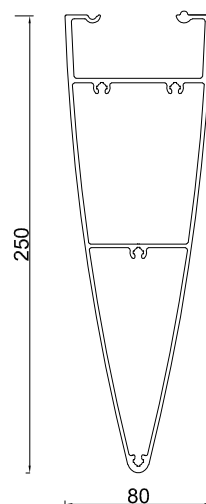

IN SYSTEM ARE INCLUDED:
ACCESSORIES , BRACKETS , ENDCAP , OTHER ELEMENTS

Listing of large-size profiles

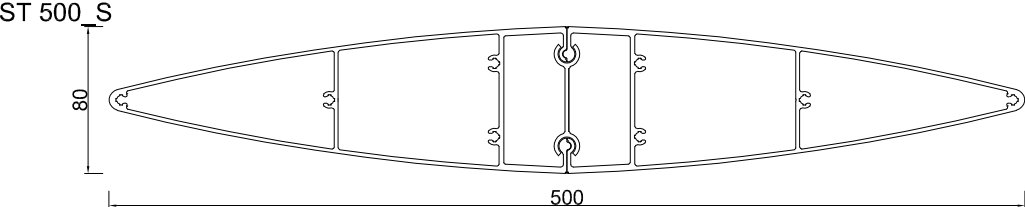
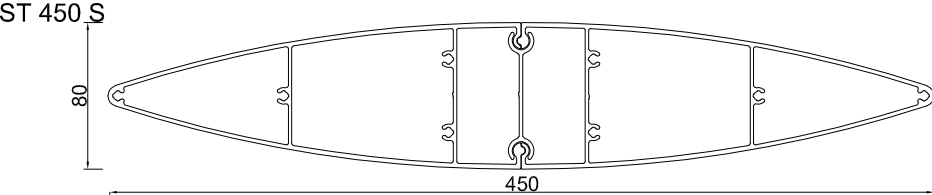
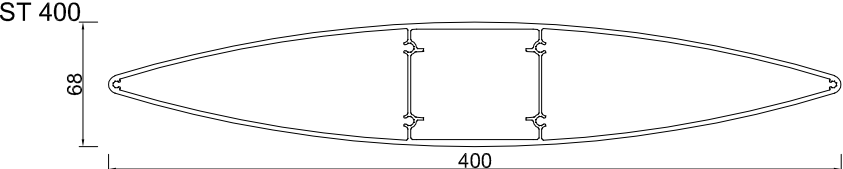
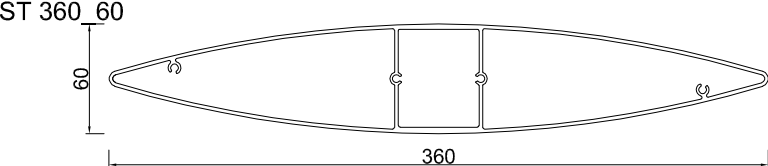
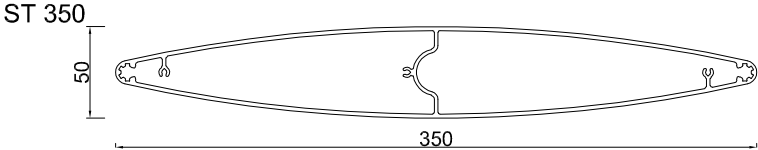

IN SYSTEM ARE INCLUDED:
ACCESSORIES , BRACKETS , ENDCAP, OTHER ELEMENTS

Listing of large-size profiles

ST SU 62 A+B

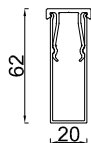

ST TR 40

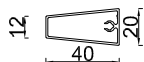

ST PR 60

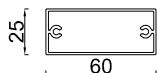

ST PR 80_20

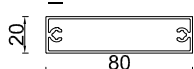

ST PR 100_20

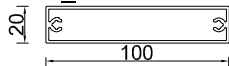

ST PR50

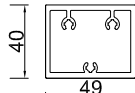

ST PR67

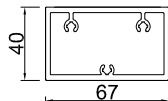

ST PR 100_40

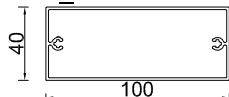

ST PR 150

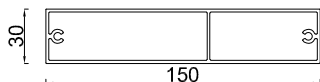

ST 175

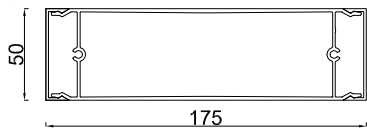

ST PR 185_45

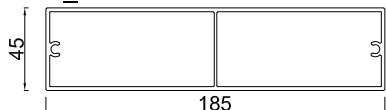

ST PR 200

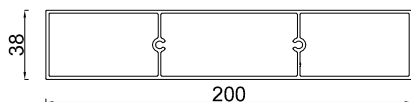

ST PR 250

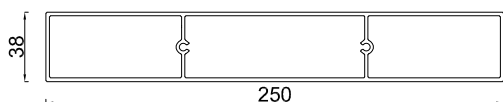

ST FR 110 INV

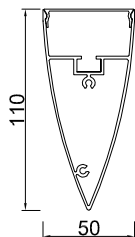

ST PR 120 INV

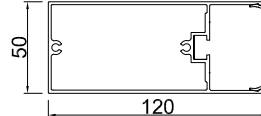

ST PR 150 INV

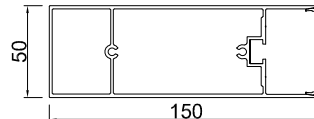

ST PR 200 INV

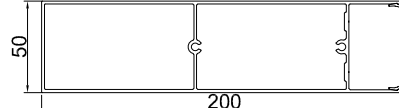

ST PR 250 INV

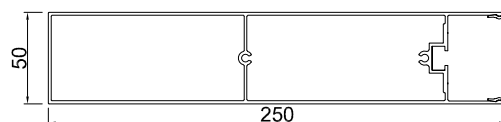

ST PR250_50

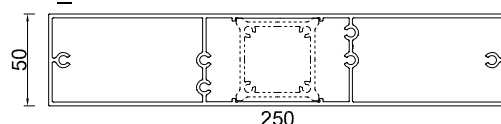

ST PR200_50

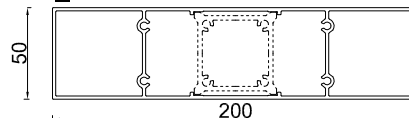

ST PR150_50

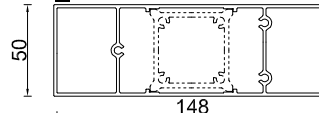

ST PR100_50

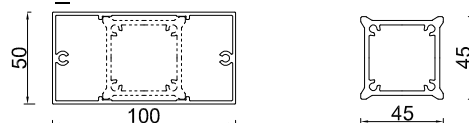

RACTAN

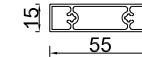

ELIPSA

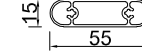

TRAPEZ

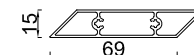

TYP145 BRISOLLEIL

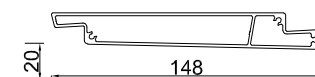

IN SYSTEM ARE INCLUDED:
ACCESSORIES , BRACKETS , ENDCAP , OTHER ELEMENTS

Listing of large-size profiles

ST PR 250_50_SOLID

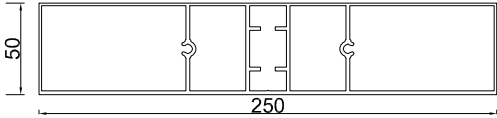

ST PR 300_16

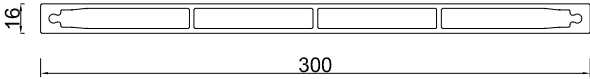

ST PR 300_34

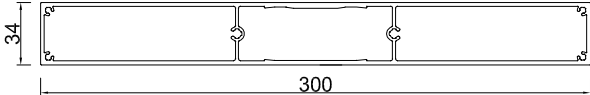

ST PR 300

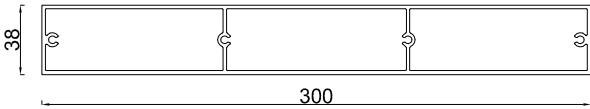

ST PR 300_52

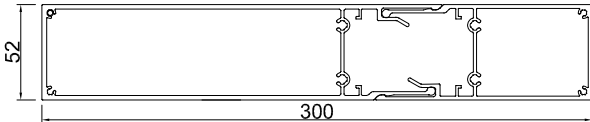

ST PR 350_50

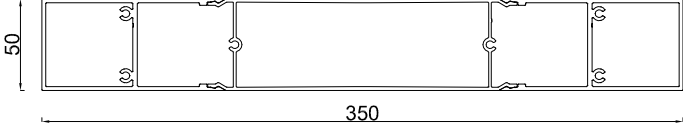

ST PR 390_40

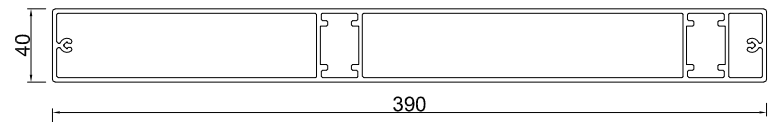

ST PR 400_52

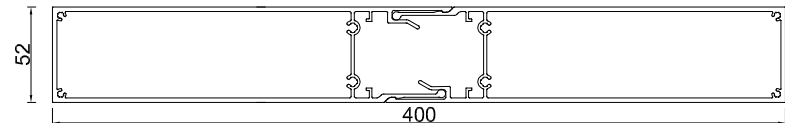

ST SEMI RACTAN 150

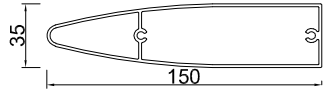

ST SEMI RACTAN 200

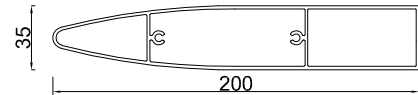

IN SYSTEM ARE INCLUDED:
ACCESSORIES , BRACKETS , ENDCAP, OTHER ELEMENTS

Listing of large-size profiles

STA 200

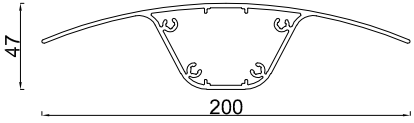

STA300

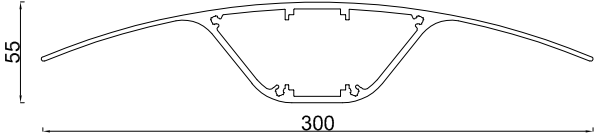

IN SYSTEM ARE INCLUDED:
ACCESSORIES , BRACKETS , ENDCAP, OTHER ELEMENTS

Listing of large-size profiles

ST PR 250 NA

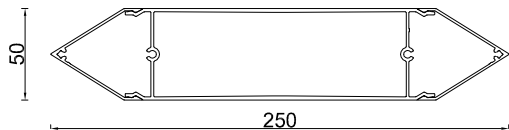

ST PR 310 VS

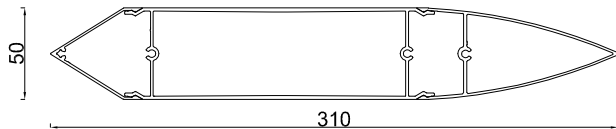

ST PR 360 SP

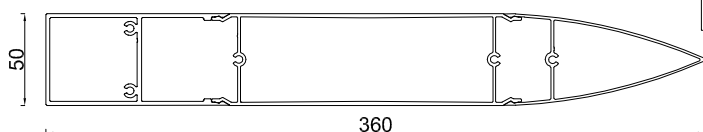

ST PR 370 SS

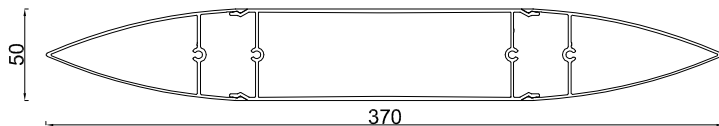

ST RB 300

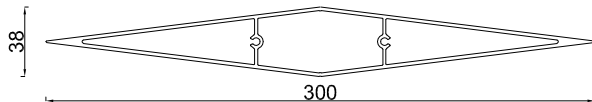

ST PR 300

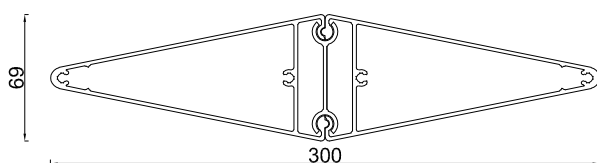

ST PS 330

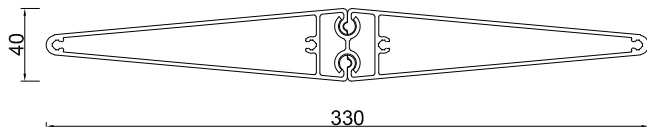

ST PA 480

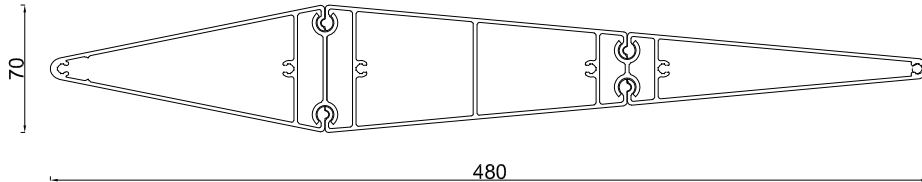

ST PS 660

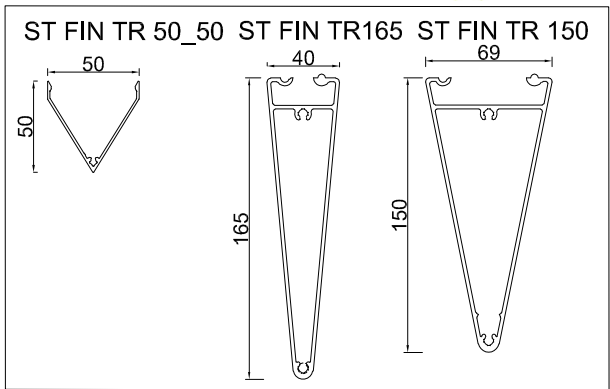
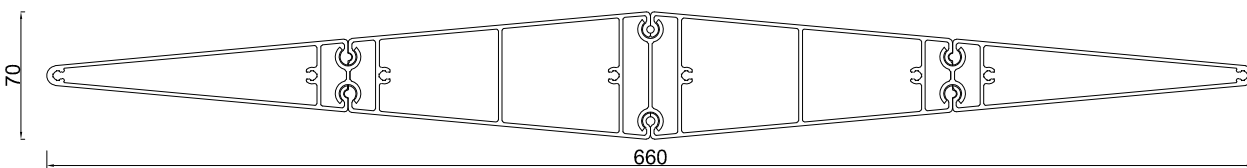

IN SYSTEM ARE INCLUDED:
ACCESSORIES , BRACKETS , ENDCAP , OTHER ELEMENTS

Listing of Z shape profiles

ST 158Z

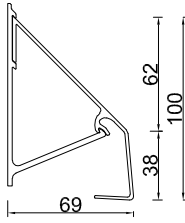

ST 100Z ECO

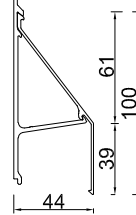

ST 150 Z

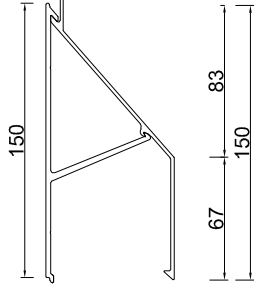

ST 100S

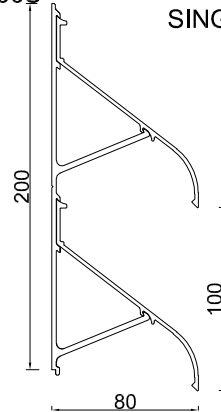

ST 100S
SINGLE GRIP

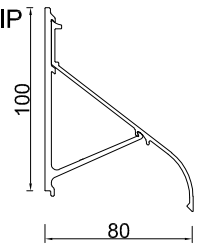

ST 122Z

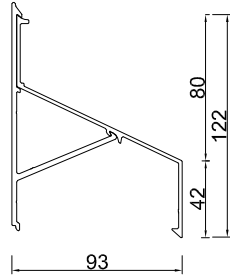

ST 100ZL

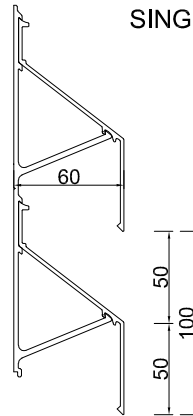

ST 100ZL
SINGLE GRIP

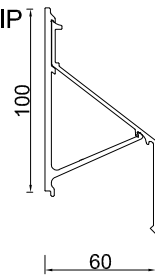

ST 130S

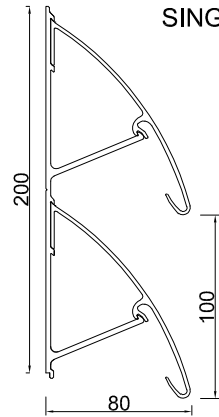

ST 130S
SINGLE GRIP

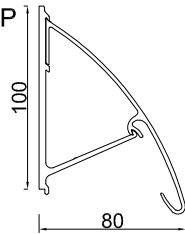

ST 75ZH

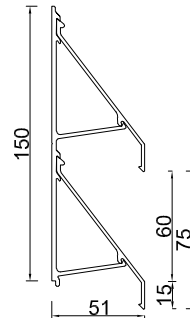

ST 100Z

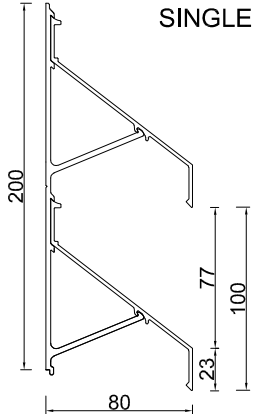

ST 100Z
SINGLE GRIP

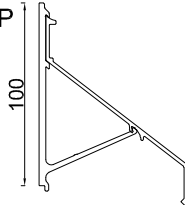

IN SYSTEM ARE INCLUDED:
ACCESSORIES , BRACKETS , ENDCAP , OTHER ELEMENTS

Listing of Z shape profiles

ST 75ZH_90

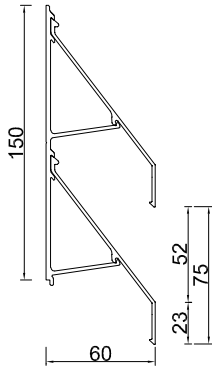

ST 67Z

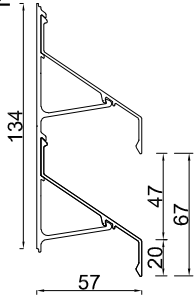

ST 67ZL

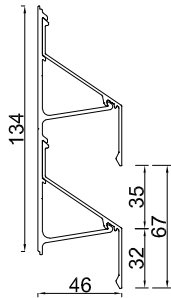

ST 67Z_0

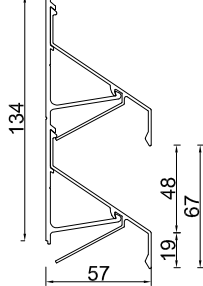

ST 60Z

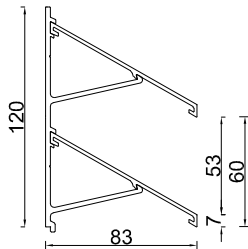

ST 50Z

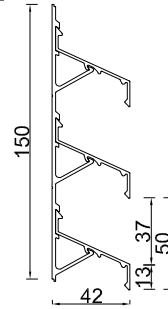

ST 50Z_0

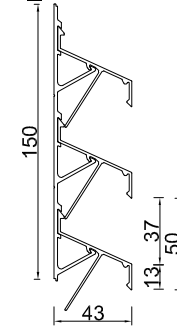

ST 50Z BREAK

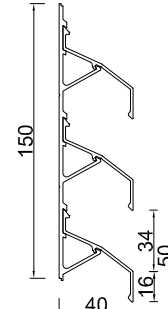

ST 50ZP

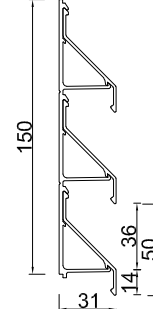

ST 50ZPL

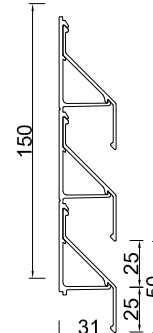

IN SYSTEM ARE INCLUDED:
ACCESSORIES , BRACKETS , ENDCAP , OTHER ELEMENTS

Listing of Z shape profiles

ST 50Z ECO

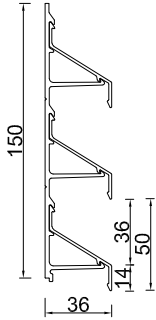

ST 333Z

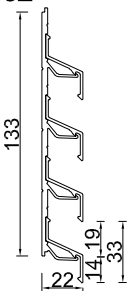

ST 40V

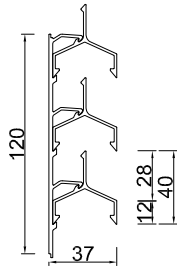

ST 40Z

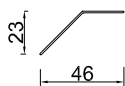

ZW 70

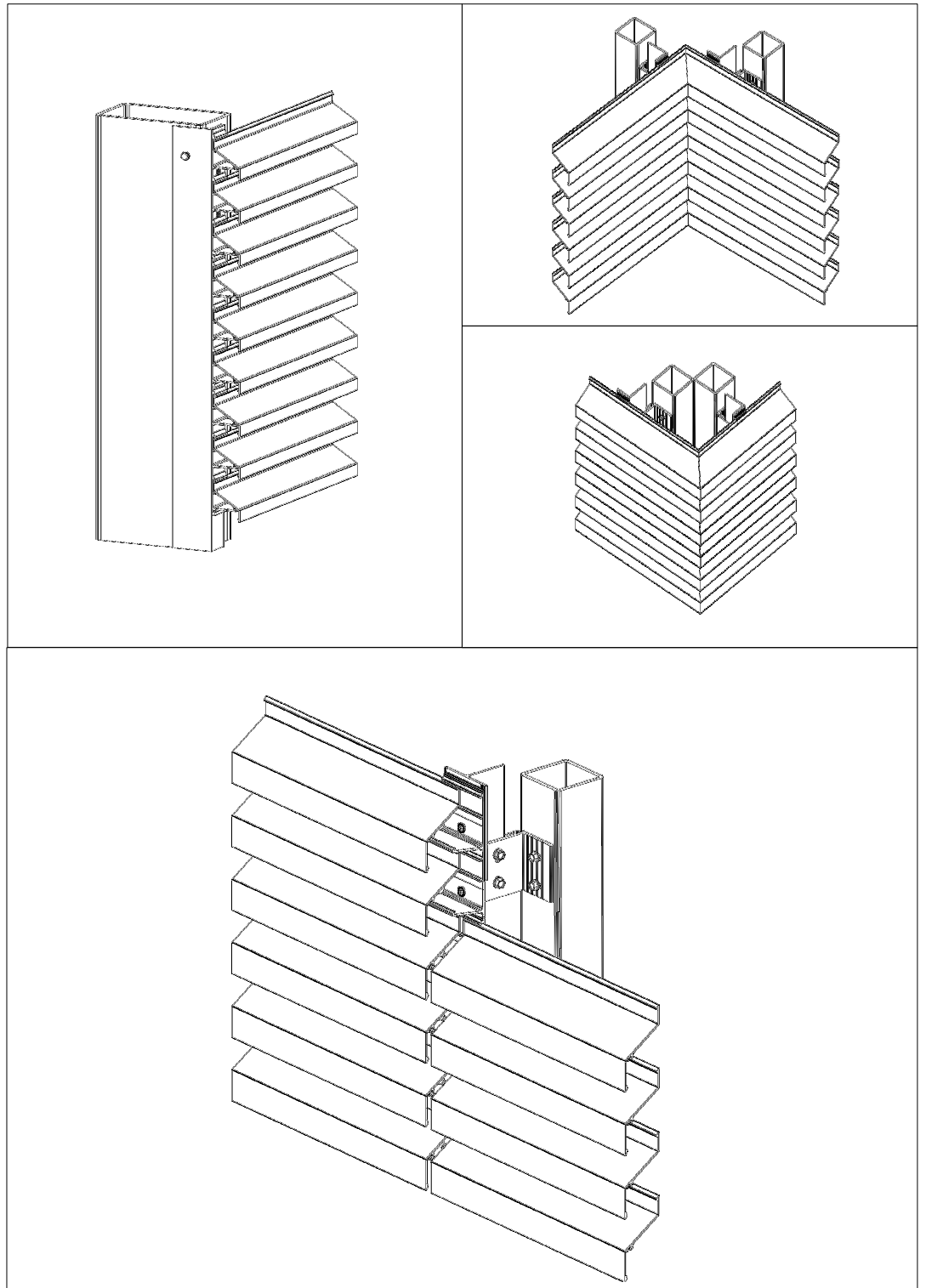
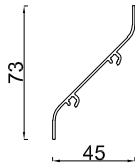

IN SYSTEM ARE INCLUDED:
ACCESSORIES , BRACKETS , ENDCAP , OTHER ELEMENTS

Listing of C shape profiles

ST 100CR

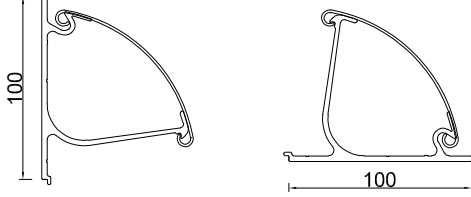

ST 100CR_U

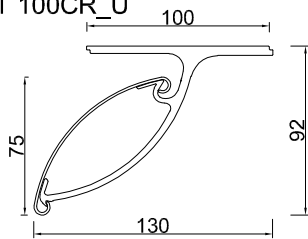

ST 85C_0

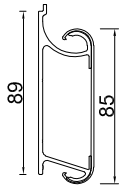

ST 85C_30

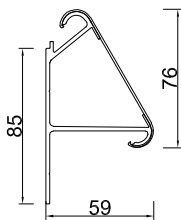

ST 85C_45

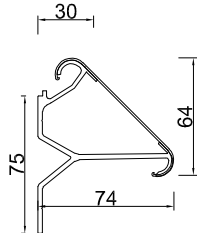

ST 100AC

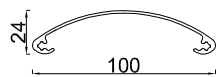

ST C100

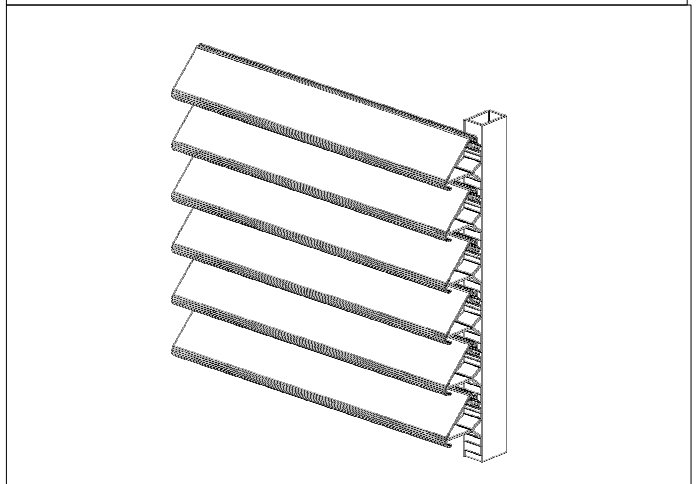
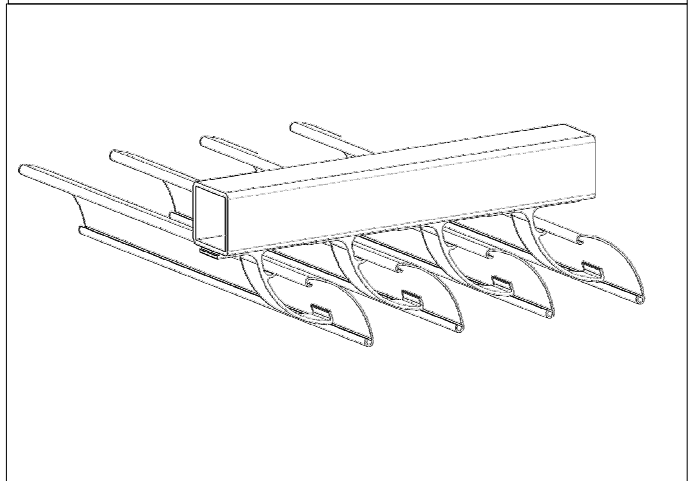
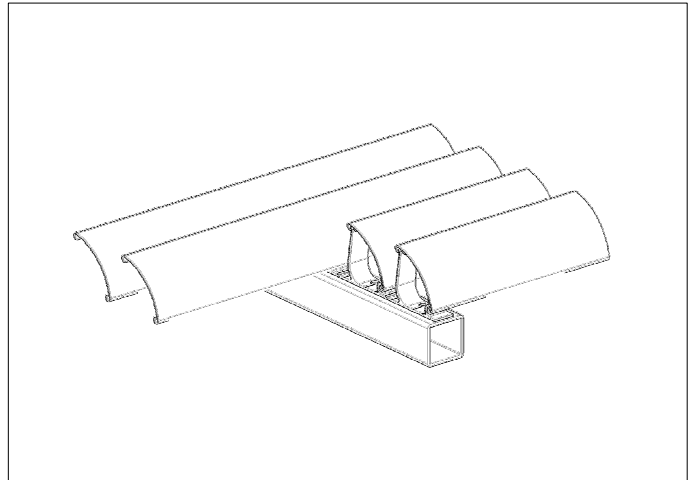
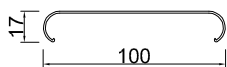

IN SYSTEM ARE INCLUDED:
ACCESSORIES , BRACKETS , ENDCAP, OTHER ELEMENTS

Listing of other shape profiles

ST ZT

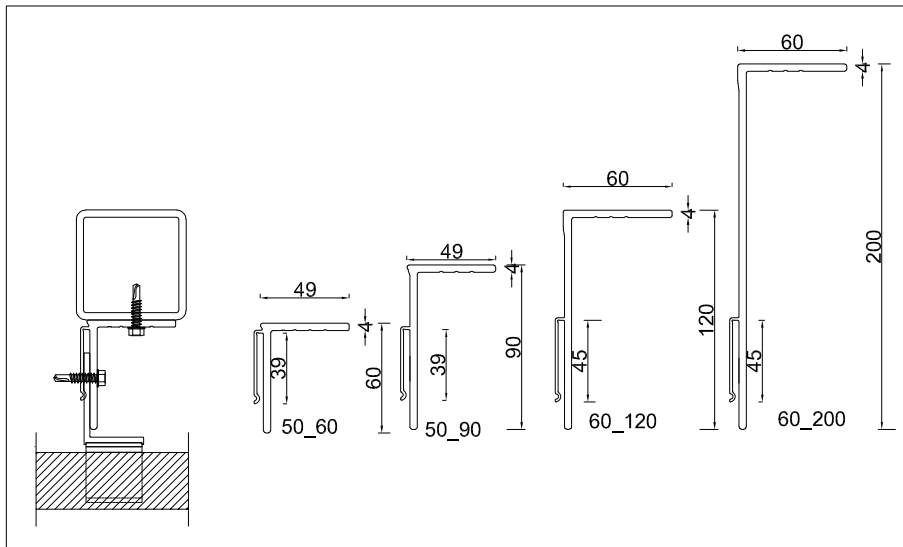
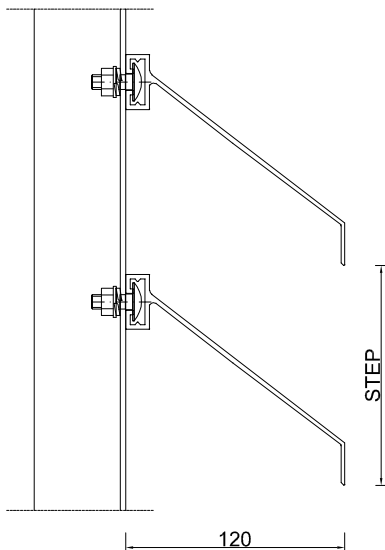

ST 250A

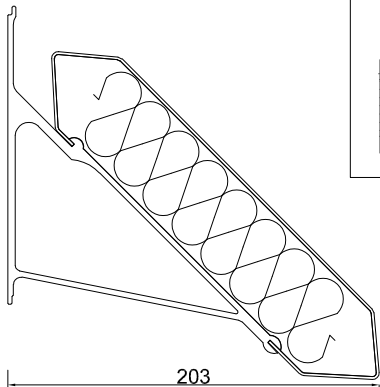

ST OK 40

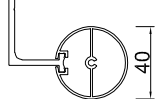

ST L50Z

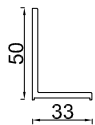

ST L50Z_60

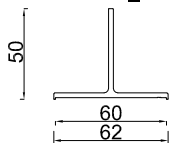

ST P50Z

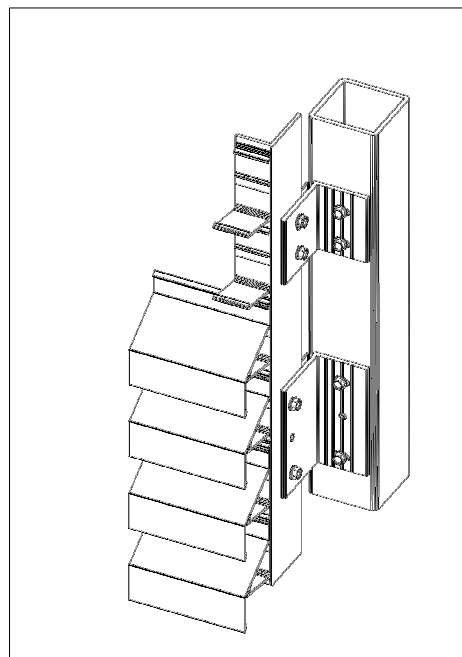
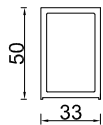

IN SYSTEM ARE INCLUDED:
ACCESSORIES , BRACKETS , ENDCAP , OTHER ELEMENTS

Profiles and brackets

ST100

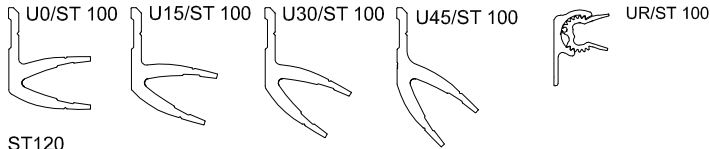

ST120

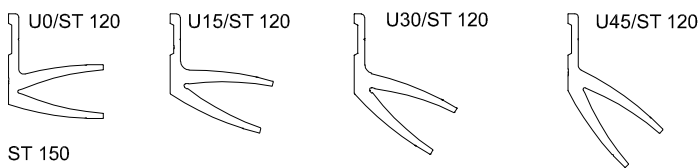
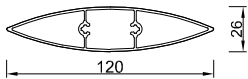

ST 150

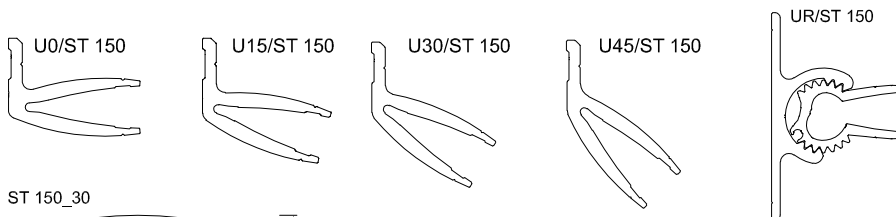
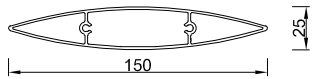

ST 150_30

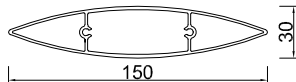

Profil ST 180

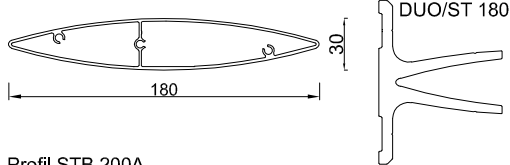

Profil STB 200A

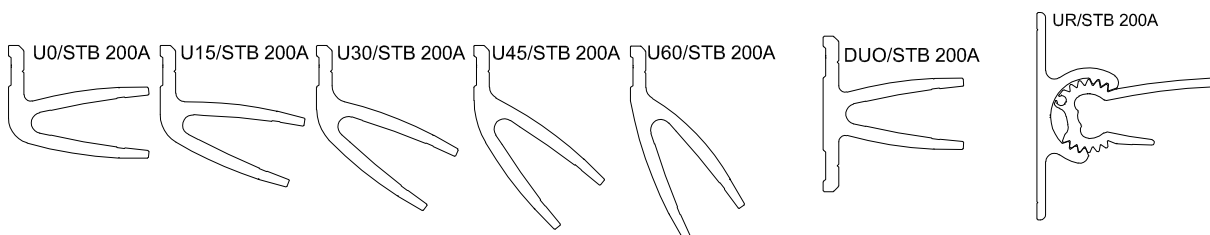
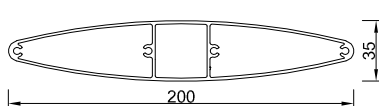

AVAILABLE ENDCAPS SHAPES FOR ALL LOUVER TYPES (OTHER ON REQUEST)

Simple endcaps

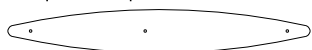

Angle endcaps (0-90°)
for mounting profiles in front of the supporting construction

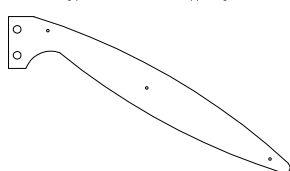

Angle endcaps (0-90°)
to install profiles in the axis of the supporting construction

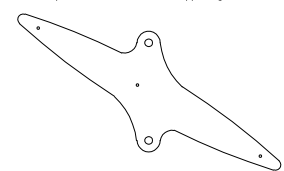

Angle endcaps (0-90°)
for mounting profiles in front of the supporting construction

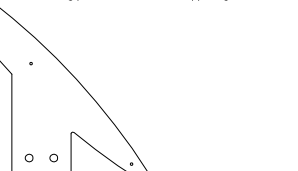

Profiles and brackets

ST 200 ECONOMY

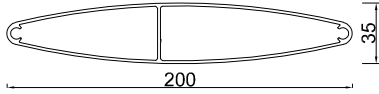

U0/STB 200 ECONOMY U15/STB 200 ECONOMY U30/STB 200 ECONOMY U45/STB 200 ECONOMY U60/STB 200 ECONOMY

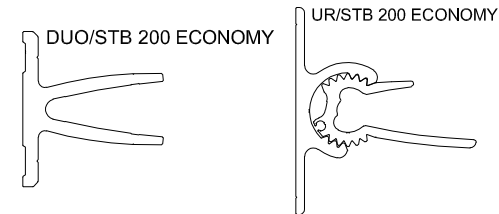
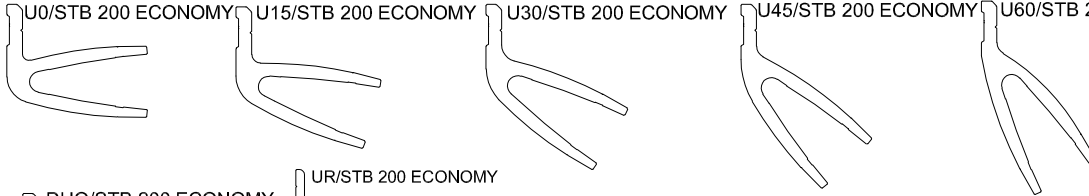

STB 250 ECONOMY

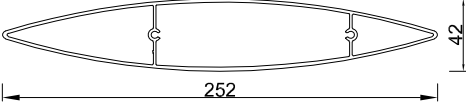

ST U0/ST 250 ECONOMY ST U15/ST 250 ECONOMY ST U30/ST 250 ECONOMY ST U45/ST 250 ECONOMY ST DUO/ST 250 ECONOMY

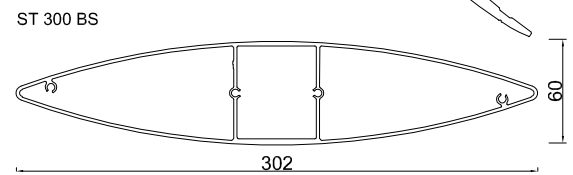
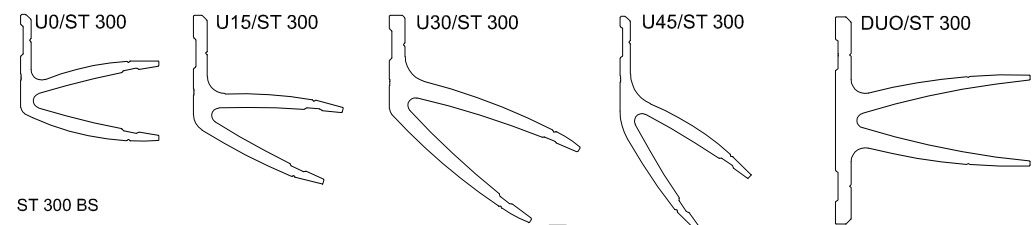
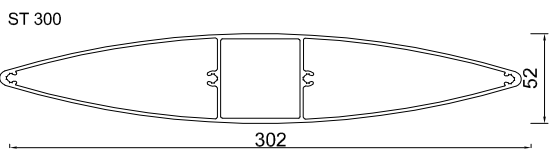
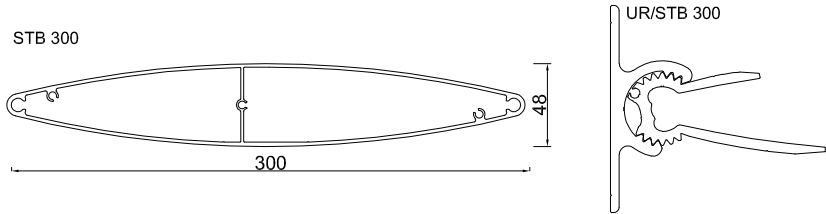
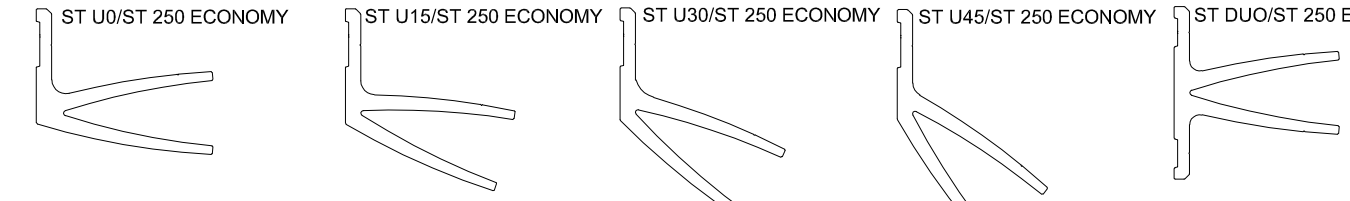

AVAILABLE ENDCAPS SHAPES FOR ALL LOUVER TYPES (OTHER ON REQUEST)

Simple endcaps

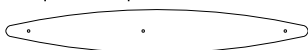

Angle endcaps (0-90°)
for mounting profiles in front of the supporting construction

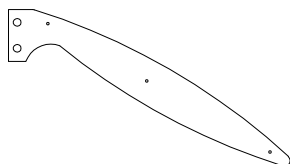

Angle endcaps (0-90°)
to install profiles in the axis of the supporting construction

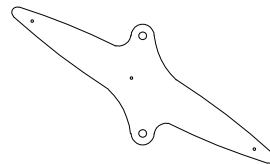

Angle endcaps (0-90°)
for mounting profiles in front of the supporting construction

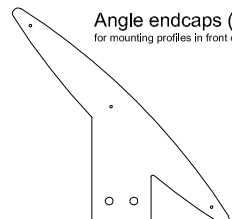

Profiles and brackets

ST 350

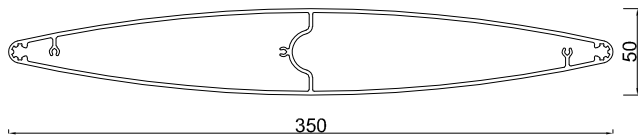

UR/ST 350

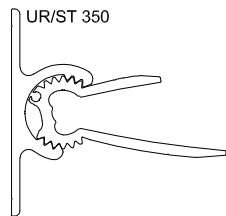

ST 360_60

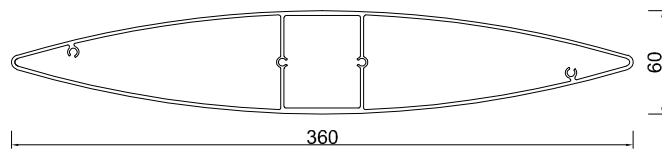

ST 400

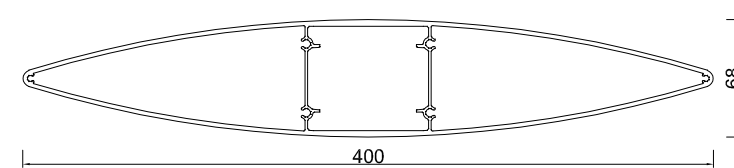

UR/ST 400

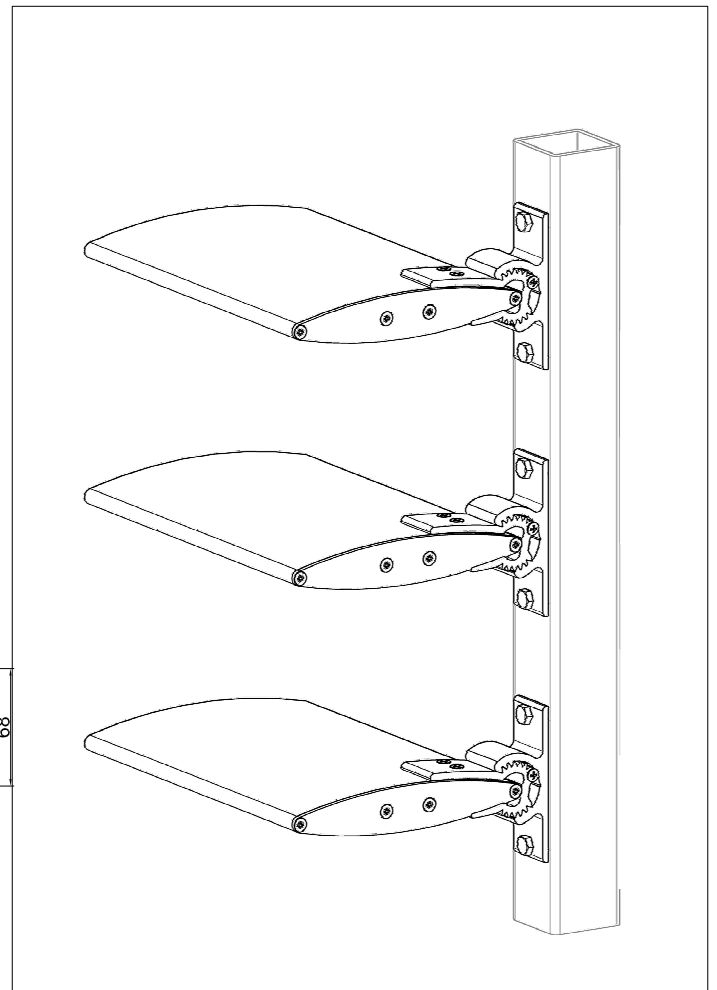
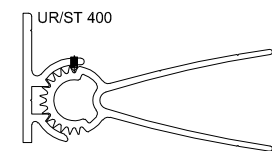

ST 450 S

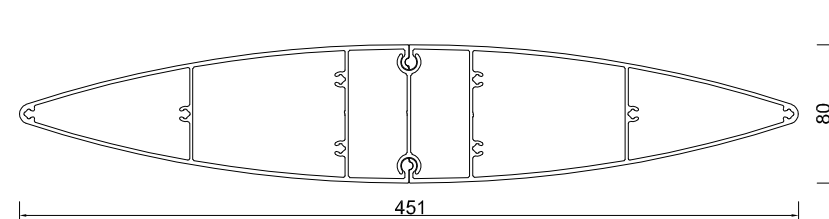

ST 500 S

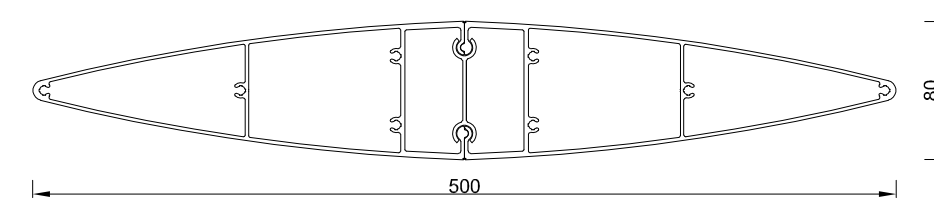

AVAILABLE ENDCAPS SHAPES FOR ALL LOUVER TYPES (OTHER ON REQUEST)

Simple endcaps

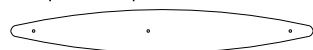

Angle endcaps (0-90°)
for mounting profiles in front of the supporting construction

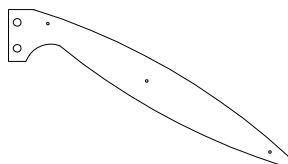

Angle endcaps (0-90°)
to install profiles in the axis of the supporting construction

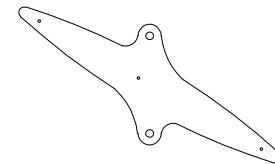

Angle endcaps (0-90°)
for mounting profiles in front of the supporting construction

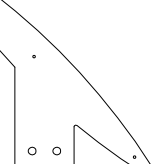

Profiles and brackets

ST PR 150

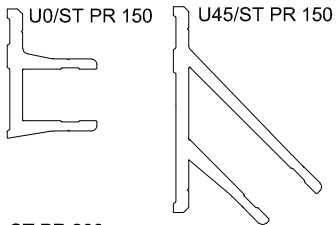
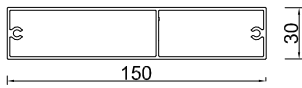

ST PR 200

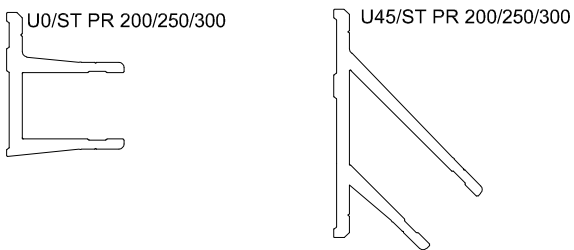
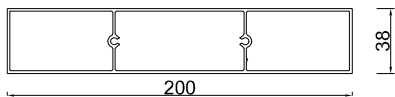

ST PR 250

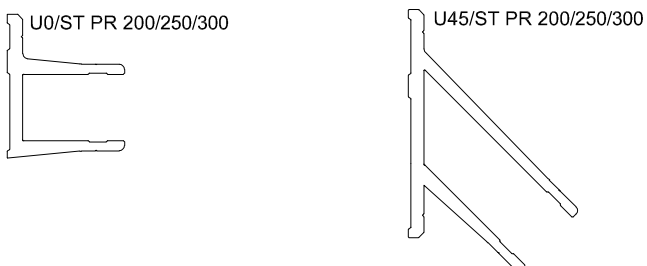
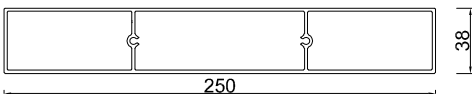

ST PR 300

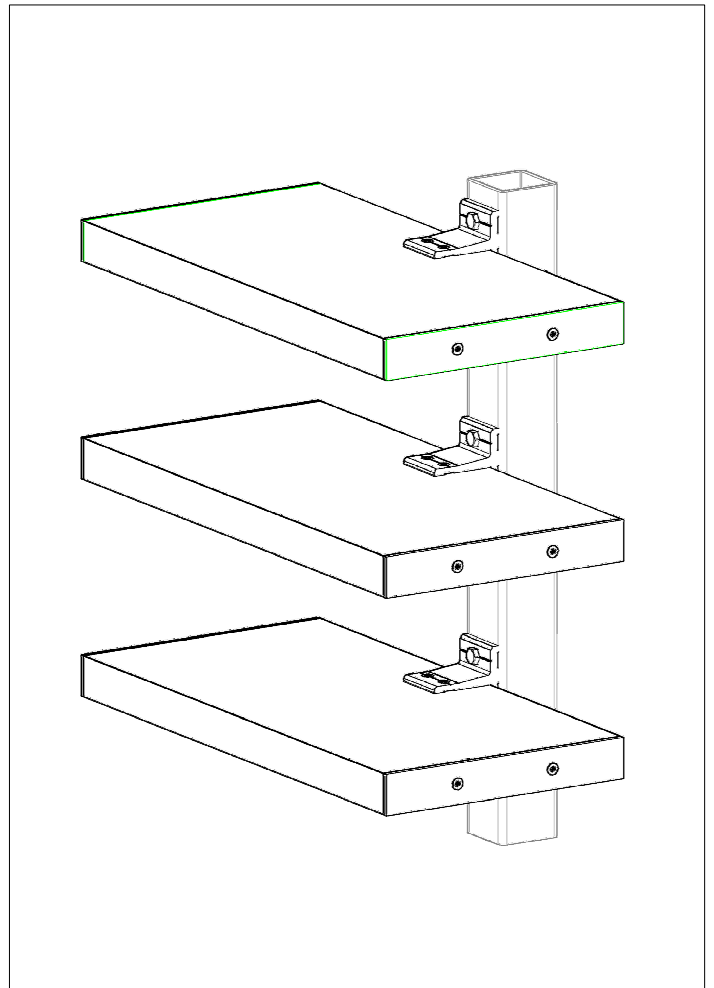
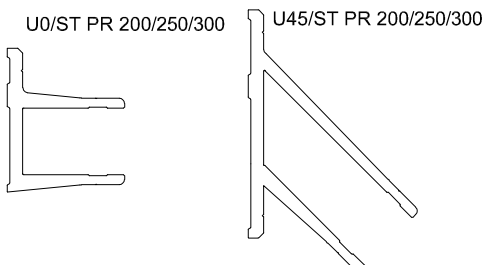
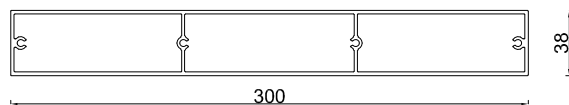

AVAILABLE ENDCAPS SHAPES FOR ALL LOUVER TYPES (OTHER ON REQUEST)

Simple endcaps



Angle endcaps (0-90°)
for mounting profiles in front of the supporting construction

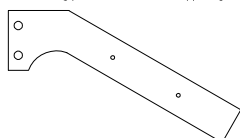

Angle endcaps (0-90°)
to install profiles in the axis of the supporting construction

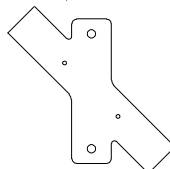

Angle endcaps (0-90°)
for mounting profiles in front of the supporting construction

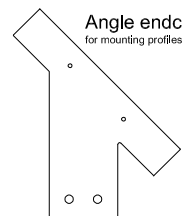

Profiles and brackets

ST SEMI RACTAN 150

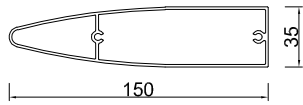

UR /ST200

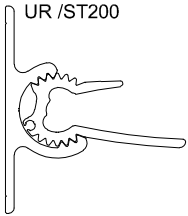

ST SEMI RACTAN 200

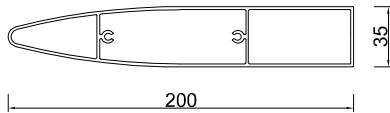

UR/ST 200

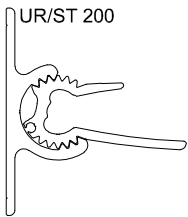

ST PR 120 INV

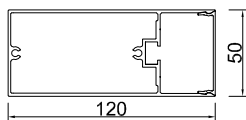

ST PR 150 INV

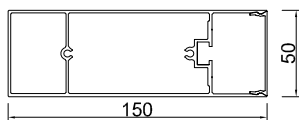

ST PR 200 INV

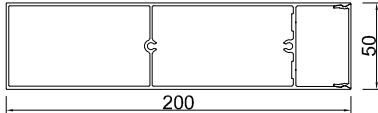

ST PR 250 INV

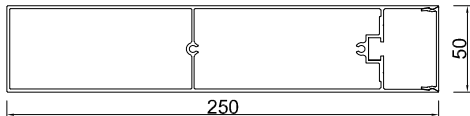

ST INV TOP

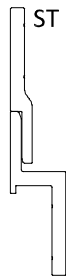

ST INV BOTTOM

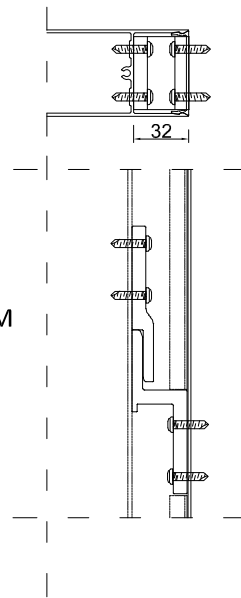

AVAILABLE ENDCAPS SHAPES FOR ALL LOUVER TYPES (OTHER ON REQUEST)

Simple endcaps



Angle endcaps (0-90°)

for mounting profiles in front of the supporting construction

